

Coating Technology

for your precision tools



You manufacture precision tools.

You have selected the ideal substrate. You've used all your experience in tool geometry and in grinding technology. You have the edge preparation perfected. Your tools are first class. Can a few μm of HiPIMS and diamond coating make the difference against the competition? To go from first-class to premium tools?

We coat cutting tools, and only cutting tools. 30 years of experience has refined tens of thousands of cutting tools every day. Together we can make good things even better.

We are the tool coating people

You are looking for:

Unique selling points to differentiate your precision cutting tools?

Economical coating solutions for high throughput rates with reliable and repeatable production runs?

A development platform for customized coatings, distinguishing your tools in the marketplace?

Let yourself be inspired by our technology

A single machine makes everything possible!

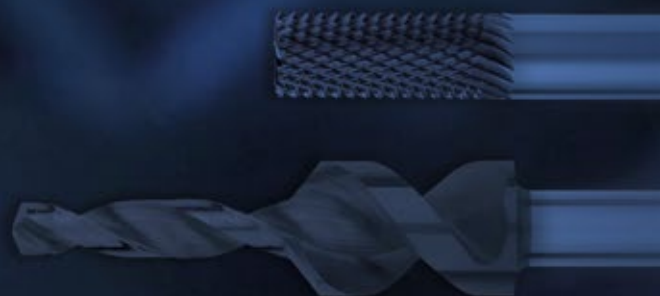



A CemeCon system is not just a machine! It's 30 years of passion for engineering combined with our daily experience from our coating service center. You don't have to settle for anything less!

5 good reasons

for CemeCon's coating technology:

1. HiPIMS is the future. Now!

No other technology can do more - from micro drills to inserts with 12 μm . No other technology is capable of coating almost any material. No system on the market is more flexible and faster!

2. We coat. You can do that, too.

With the appropriate transfer of know-how, we ensure that you can do what we do every day. Unmatched performance – premium coatings for cutting tools. At CemeCon you get not only the coating machines from the market and technology leader, but also the ability to win the race for the markets – all directly from our coating service.

3. 2 $\mu\text{m}/\text{h}$ HiPIMS and a technology, which is open to your ideas

A workhorse for your production with the highest deposition rate on the market, and at the same time a platform for visionaries that can produce almost any material.

4. The original is the best!

CemeCon was the first to produce and patent HiPIMS tool coatings on an industrial scale. Patented coatings provide you with unique selling points. Some things can only be used by CemeCon and some may only be used by CemeCon. Each of our customers enjoys this advantage!

5. Global availability, local strength!

CemeCon is very individually active on-site, always with the same quality standards, the same premium products and at the same level of advice and service. Worldwide.



The future is where your markets prosper.
HiPIMS delivers maximum flexibility.
All coating materials and all substrates
are possible!



What requirements will your customers ask for in the precision tools of tomorrow?

Which coatings will be relevant? The HiPIMS technology delivers security here.

With HiPIMS any material can be coated. This means an unlimited material variety

due to the possible combinations of the elements on the periodic table for production and for proprietary development of coatings.

On HSS, carbide, CBN and ceramic – all substrates can be coated!

Future security for your products.
Future security for your investment.

coatings.cemecon.de



**Learn more about the
CemeCon Premium
Coating materials**

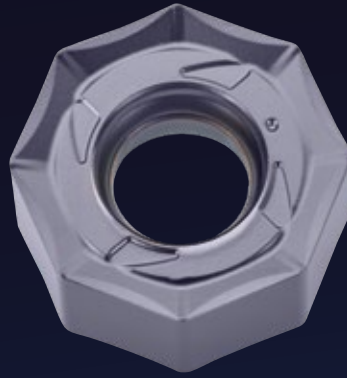

Milling insert
for machining
of steel



Solid carbide endmill
for machining
of stainless steel



HSS tap drill
for steel, cast iron, stainless

CC800[®]

HiPIMS

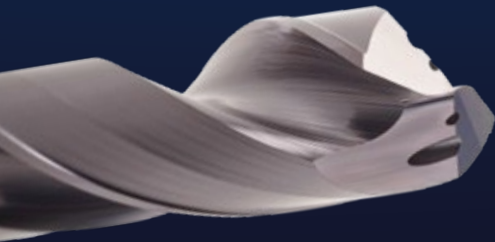

Solid carbide drill
for machining
of steel and cast iron



Milling insert
for machining
of stainless steel



Ball nose endmill
for the die and
mould construction



Turning insert
for machining of non-ferrous
metals and aluminium

Micro tools
for use in the
Medical technology (implants)



One coating plant,
unlimited coatings.
Even your own!

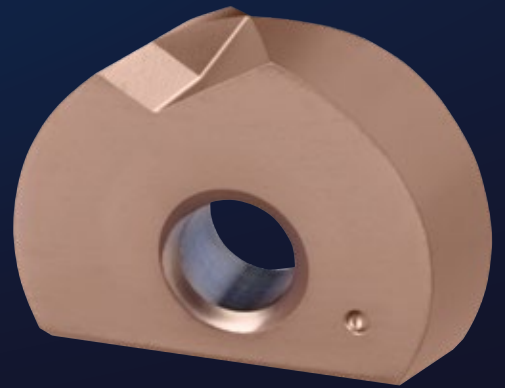

Insert
for hard milling
for die and mould making

Grooving insert



Solid carbide endmill
for machining
of non-ferrous metals
and aluminium

Nearly 100 % metal ionization without droplets.

Smooth, no droplets. A high-energy plasma precisely adapted to your tool geometry. CemeCon holds the fundamental patents for HiPIMS technology for cutting tools.

12 μm

FerroCon®Quadro

10 μm

8 μm

6 μm

4 μm

2 μm

HiPIMS sets new standards and combines the advantages of all current technologies.

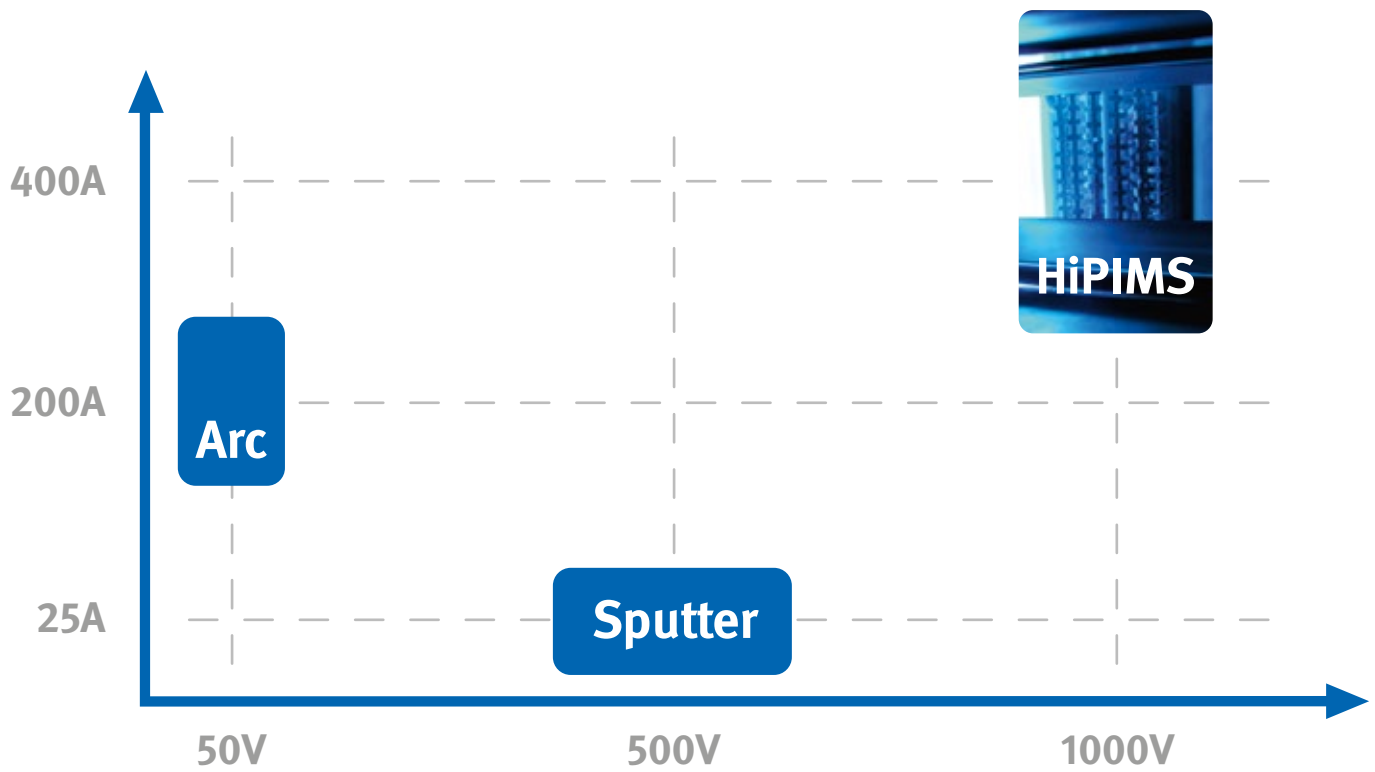

- + Flexibility
- + Coating thicknesses up to 12 μm
- + Dense structure of the coating
- + Residual stress management for low compressive stresses in the coating
- + Smoothness, 100 % without droplets
- + Perfect for micro tools
- + Coating adhesion
- + Hardness and toughness at the same time
- + Deposition rate
- + Coating distribution

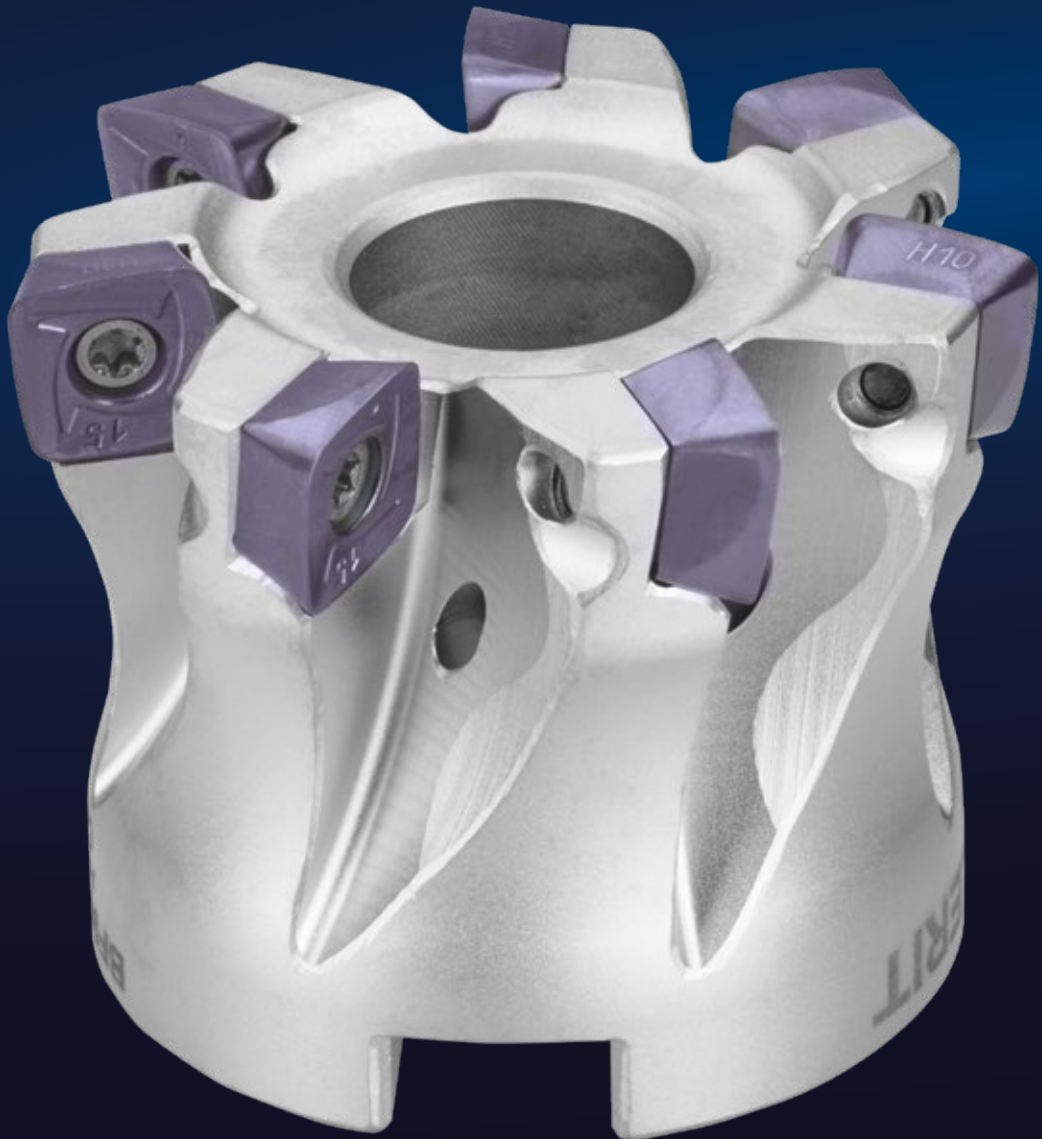

12 μm

A new horizon in the coating technology for cutting inserts

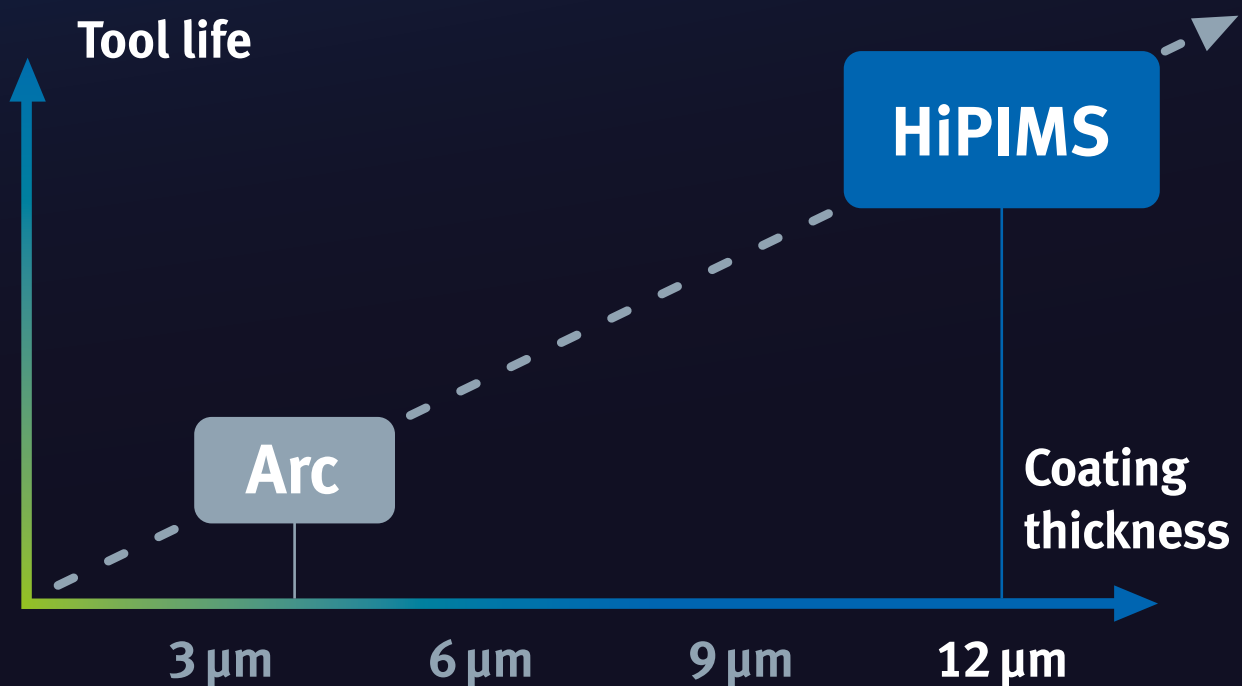



GEME
The Tool Co.

When the requirements for the coatings become more and more individual and the lot sizes become smaller, it needs systems to produce precision coatings reliably and quickly. With CC800® HiPIMS, integrated into your own production you manage up to 5 batches a day. Each one with a different coating specification.

2 $\mu\text{m}/\text{h}$

Fastest and most flexible system on the market.

HiPIMS deposition rates of 2 $\mu\text{m}/\text{h}$.
Fast changeover, high productivity!

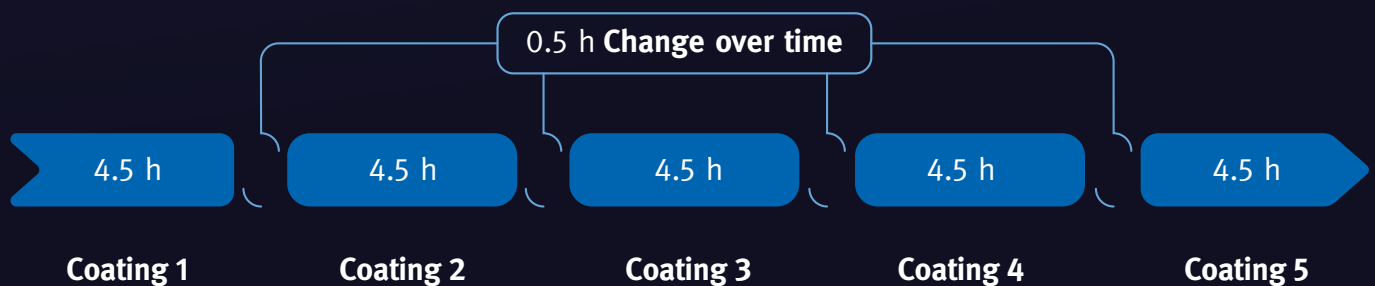

CC800[®] HiPIMS

The CC800[®] HiPIMS is capable of handling all existing CemeCon coatings and almost all other PVD coatings available on the market, featuring coating rates up to 2 $\mu\text{m}/\text{h}$ in pure HiPIMS mode; a range of coating thicknesses from 1 μm to currently 12 μm ; and capacity levels of up to 1,800 shank tools or 5,000 inserts.

It is the fastest, most flexible and most economical production system ever designed and the perfect platform for the development of customer-specific processes. This enables users to differentiate their tools in the marketplace and achieve a competitive advantage.



CC800[®] HiPIMS

HiPIMS HIGH POWER IMPULSE MAGNETRON SPUTTERING

CATHODES



HiPIMS



DC

BIAS



HiPIMS



DC



PULS



Coating volume, Ø x h	[mm]	Ø400 x 400
Substrate table, Ø x Ø Satellites x number of satellites	[mm], piece	Ø400 x Ø130 x 6
Cathodes	piece, [mm]	6 x 500 (4 of which optionally HiPIMS/DC and 2 further DC; all cathodes are equipped with shutters)
Maximum substrate dimensions, Ø x h	[mm]	Ø400 x 800
Capacity drill, Ø6 mm x 60 mm	piece	1,800
Capacity insert, 12,7 mm x 3,5 mm	piece	4,920
Loading	[kg]	250
Deposition rate	µm/h	2 µm/h in pure HiPIMS
Cycle time for 3 µm FerroCon®*	[h]	4.5
Technologies		HiPIMS and sputtering with booster technology. All established CemeCon coatings are possible.
Substrate pretreatment (plasma etching)		Booster, MF and HiPIMS etching
Electrically conductive coatings		yes
Electrically non-conductive coatings		yes
Electrically non-conductive substrates		yes
Connected load	[kW]	80
Power consumption per batch for 3 µm FerroCon®*	[kWh]	120
External dimensions (w x l x h)	[mm³]	1,450 x 3,350 x 2,200

* pure HiPIMS coatings on 10 mm milling cutter, full load, triple rotation

On the way to your own Premium Coating

Pretreatment of the tools

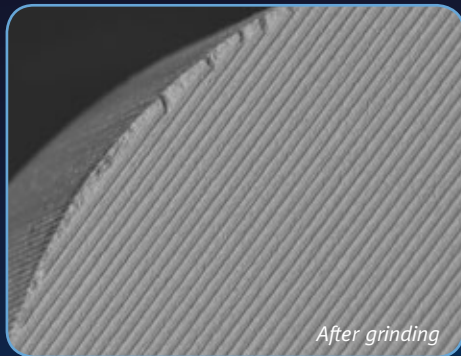

The right coating material



The best coating system



Turnkey coating line



Technology transfer



100% competitive advantage

On request, CemeCon supplies the complete package consisting of substrate pretreatment, coating system and added periphery. The unit of plant engineering, proven process and the training of your employees in our coating center facilitates your entry into the coating technology. It also makes the difference from any other technology supplier!

Consumables with „built-in“ process knowledge!

CemeCon targets are designed for maximum performance and deposition rate. Our target materials with the patented plug technology keep their full efficiency from the first to the last batch.



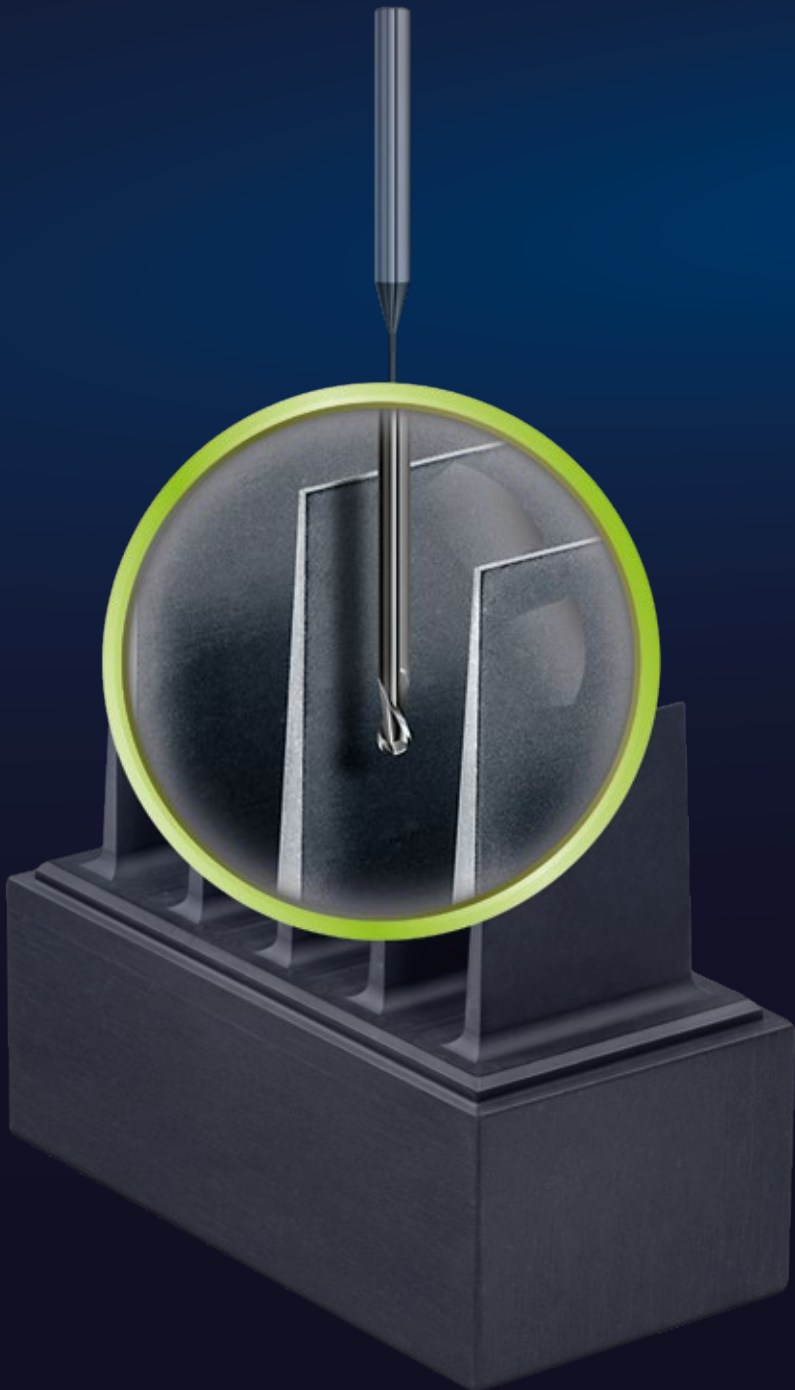



Diamond coatings from CemeCon

The hardest material in the world as a coating material for maximum wear protection in the machining of graphite, fiber reinforced plastics (CFRP/composites) and abrasive non-ferrous metals.

The patented CemeCon multilayer technology ensures maximum stability by interlocking the individual layers within the coating. Through their extremely high hardness – with up to 10.000 HV0,05 close to natural diamond – all coatings of the product group CCDia® prove extremely wear-resistant. CCDia®-coating significantly increases the

performance of shank tools and cutting inserts made of solid carbide. The high thermal conductivity of the diamond coating ensures rapid heat dissipation, which is important for the processing of temperature-sensitive materials such as CFRP and GRP. This is enormously important and enables a higher processing speed when machining. All these characteristics make the coating materials of the CCDia® series the first choice in the machining of graphites, composites, non-ferrous metals, green bodies and ceramics.

Fibers are precisely cut in aircraft CFRP and stacks with the patented Multilayer diamond coating technology from CemeCon. Hole after hole can be performed with repeatable accuracy, without fiber protrusion and with the tightest tolerance for a carefree riveting process.

CCDia®Carbonspeed is ideal for complex 3D contours in graphite moulds when bending glass for curved displays.

New tool business in the growing dental market through diamond coatings: Your tools with CemeCon Diamond produce dentures directly from a ZrO₂ blank.



CC800[®] Diamond

The hardest coating material in the world – real diamond crystals. With the CC800[®] Diamond, extremely smooth and outstandingly adhesive nanocrystalline, crystalline or multilayer diamond coatings can be applied on more than 80 different hard metal types.

The hot-filament process is perfect for complex three-dimensional tools, giving them a particularly homogeneous coating thickness distribution with narrow tolerances. Despite its compact external dimensions, the CC800[®] Diamond is the market's largest capacity, fully automatic system for diamond coatings. Three independently operating coating chambers make this system very flexible and economical.





As the market leader, CemeCon offers sustainable Diamond coatings for the challenges in the machining of graphite, in aviation, 3C (computer, communication and consumer electronics) industry and medical technology.

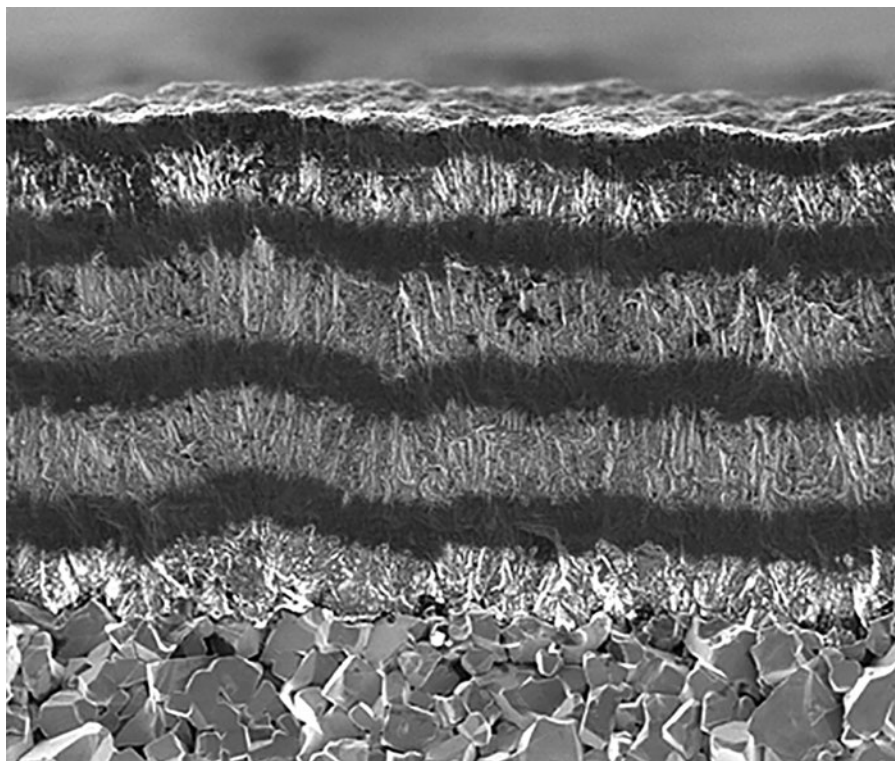

Smooth, adherent and excellently interlocked thanks to patented Multilayer diamond coating

CC800[®] Diamond

Coating space, number x (w x l x h)	[mm ³]	3 x (50 x 560 x 70)
Maximum substrate dimensions, Ø x h	[mm]	Tools 30 x 500
Loading	[kg]	250
Process method		Hot-Filament
Electrically conductive coatings		yes
Electrically non-conductive coatings		yes
Electrically non-conductive substrates		yes
Connected load	[kW]	98
External dimensions (w x l x h)	[mm ³]	1,260 x 3,600 x 2,070

We are flattered...

... when our coating lines are perceived as the racing cars on the market. Yes, they are fast, they are agile, they are durable under extreme conditions and they provide everything that winners need to win.

The beauty of it is, you don't need a racing driver's license, because our plant's performance feels like a normal car.

Relaxed on the top step of the podium!

Know-how transfer at CemeCon in the world's largest coating center. Premium also means a head start in knowledge and thus competitive advantages. In every detail!





Think Global – Act Local

Markets, customer requirements and cultures in Asia, Europe and the USA differ. CemeCon is on site very individually active - always with the same quality standards, the same premium products and at the same high advice and service level. And that worldwide.



cemecon.de/contact



One click away!

Never before has the decision for the right coating technology been so simple!

HiPIMS (High Power Impulse Magnetron Sputtering) is sputtering with dramatically increased energy – at full control of energy input - and combines the advantages of all PVD coating technologies and processes. HiPIMS produces smooth, droplet-free and low-stress coatings in an almost unlimited variety.

	Arc	CVD	HiPIMS
Surface	Droplets	Rough	Smooth
Coating temperature	500 °C	1000 °C	500 °C
Max. coating thickness	4 µm	10–15 µm	12 µm
Residual stresses of the coating	High compressive	Tensile stress	Residual stress management for low compressive stress
Toughness of the coating	High	Low	Very high
Ease of production	Yes	No (precursor)	Yes
Flexibility	Low	None	High (all materials, all substrates)
Mini tools	No	No	Yes